

**WILDSTAR
FARM
EQUESTRIAN
FACILITY**

SHERRORN
MASSACHUSETTS

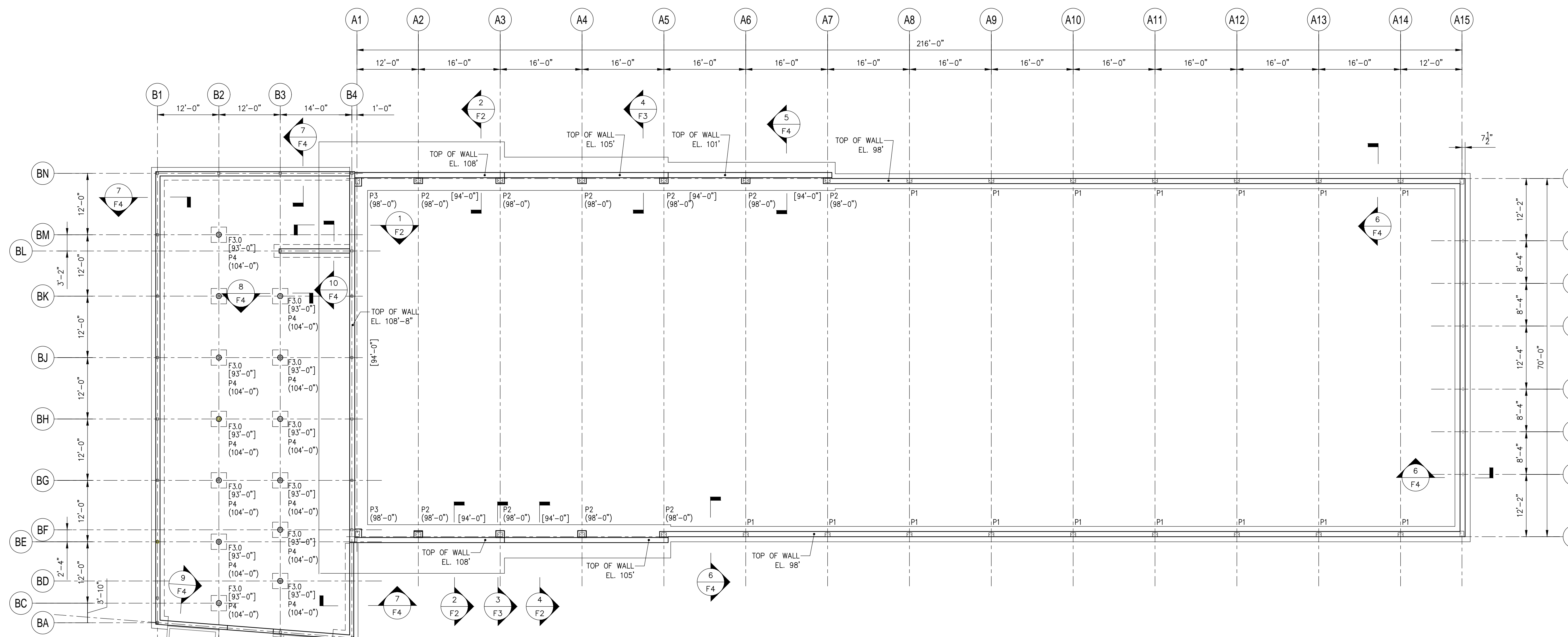

Polly Kornblith and Michael Newman
16 Nelson Hill Lane
Sherrorn, Massachusetts, 01770



EXISTING WOOD
FRAMED BARN
SHORE EXISTING
BARN STRUCTURE
AS REQUIRED

FOUNDATION PLAN

SCALE: 1/8"=1'-0"

NOTES:

1. TOP OF BARN SLAB EL. 108'-0".
2. [0'-0"] INDICATES APPROXIMATE BOTTOM OF FOOTING ELEVATION. ELEVATIONS POSTED ARE A MINIMUM, GC MAY INCREASE DEPTH AND STEP FOOTINGS IN ACCORDANCE WITH STEPPED FOOTING DETAIL ON DRAWING F5.
3. (0'-0") INDICATES TOP OF PIER ELEVATION.
4. FOR PIER DETAIL, SEE DRAWING F1.
5. FOR WALL SECTIONS, SEE DRAWINGS F2 & F3 & F4.
6. FOR GENERAL NOTES & TYPICAL CONCRETE DETAILS, SEE DRAWING F5.
8. ALL DIMENSIONS SHOWN HAVE BEEN GENERATED BY THE ARCHITECT AND SHOULD BE VERIFIED WITH THE LATEST SET OF ARCHITECTURAL DRAWINGS PRIOR TO CONSTRUCTION.
9. FOR ARENA STRUCTURE, REFER TO DRAWINGS PREPARED BY CALHOUN.

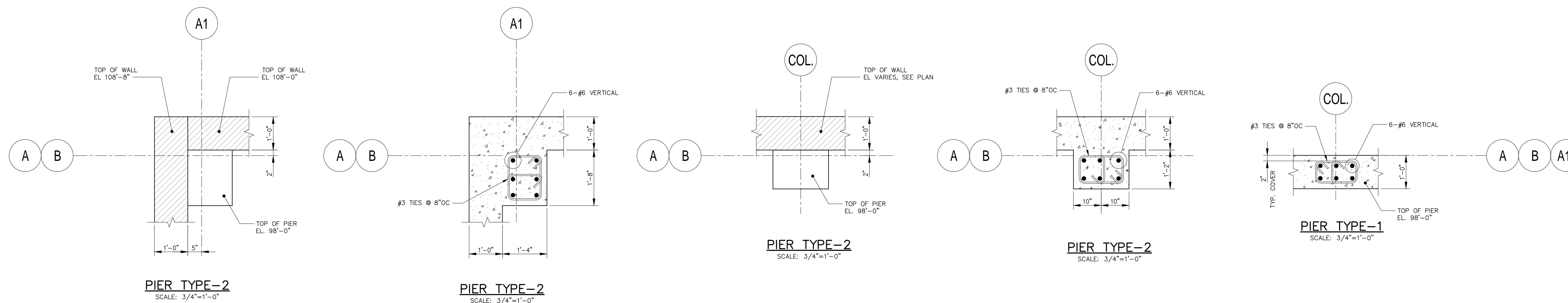

TYPICAL PIER DETAILS

KEYPLAN

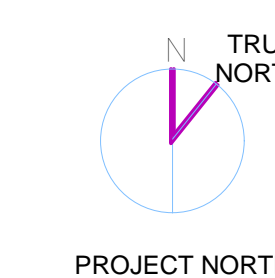

Scale:

Job No.:

Drawn By: MRF

Date:

F1

**WILDSTAR
FARM
EQUESTRIAN
FACILITY**

**SHERORN
MASSACHUSETTS**



Polly Kornblith and Michael Newman
16 Nason Hill Lane
Sherborn, Massachusetts, 01770

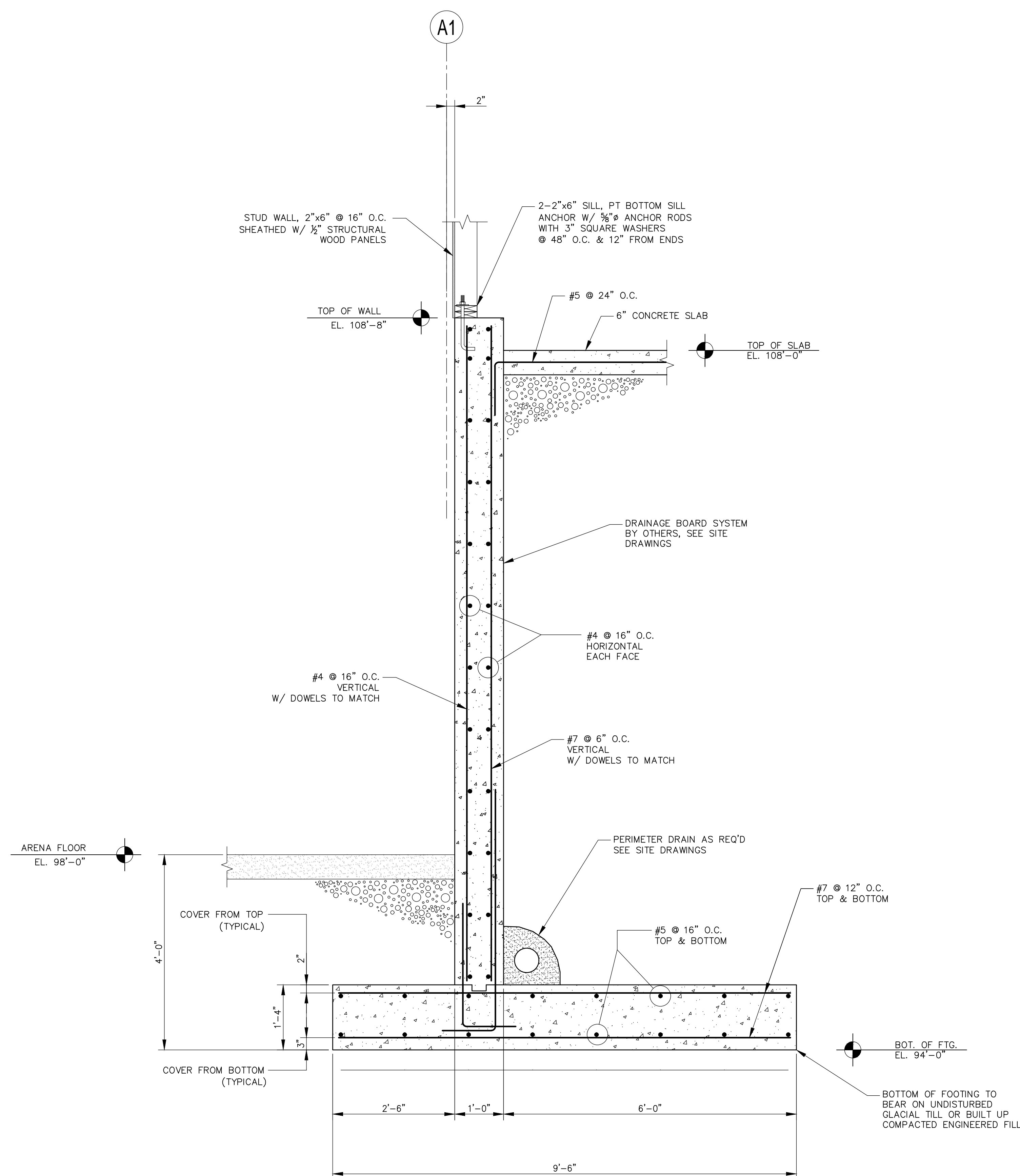
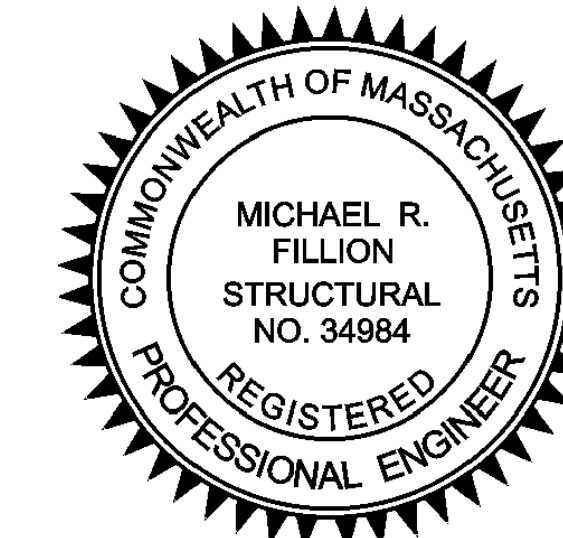

1
SECTION
SCALE: 3/4"=1'-0"

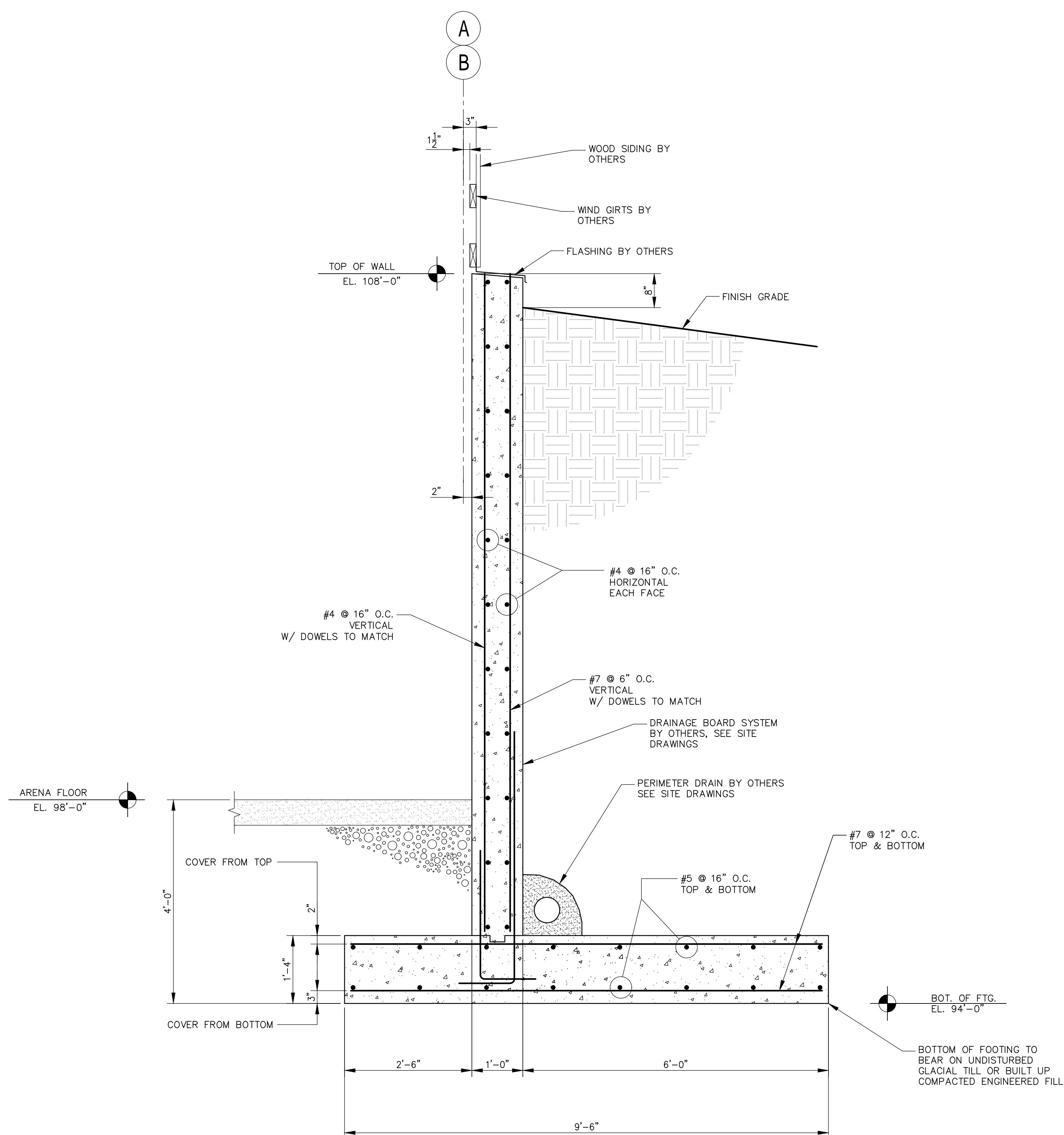

2
SECTION
SCALE: 3/4"=1'-0"

KEYPLAN

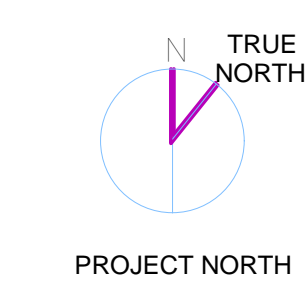

Scale:
Job No.:
Drawn By: MRF
Date:

F2

**WILDSTAR
FARM
EQUESTRIAN
FACILITY**

SHERRORN
MASSACHUSETTS



Polly Kornblith and Michael Newman
16 Nason Hill Lane
Sherrorn, Massachusetts, 01770

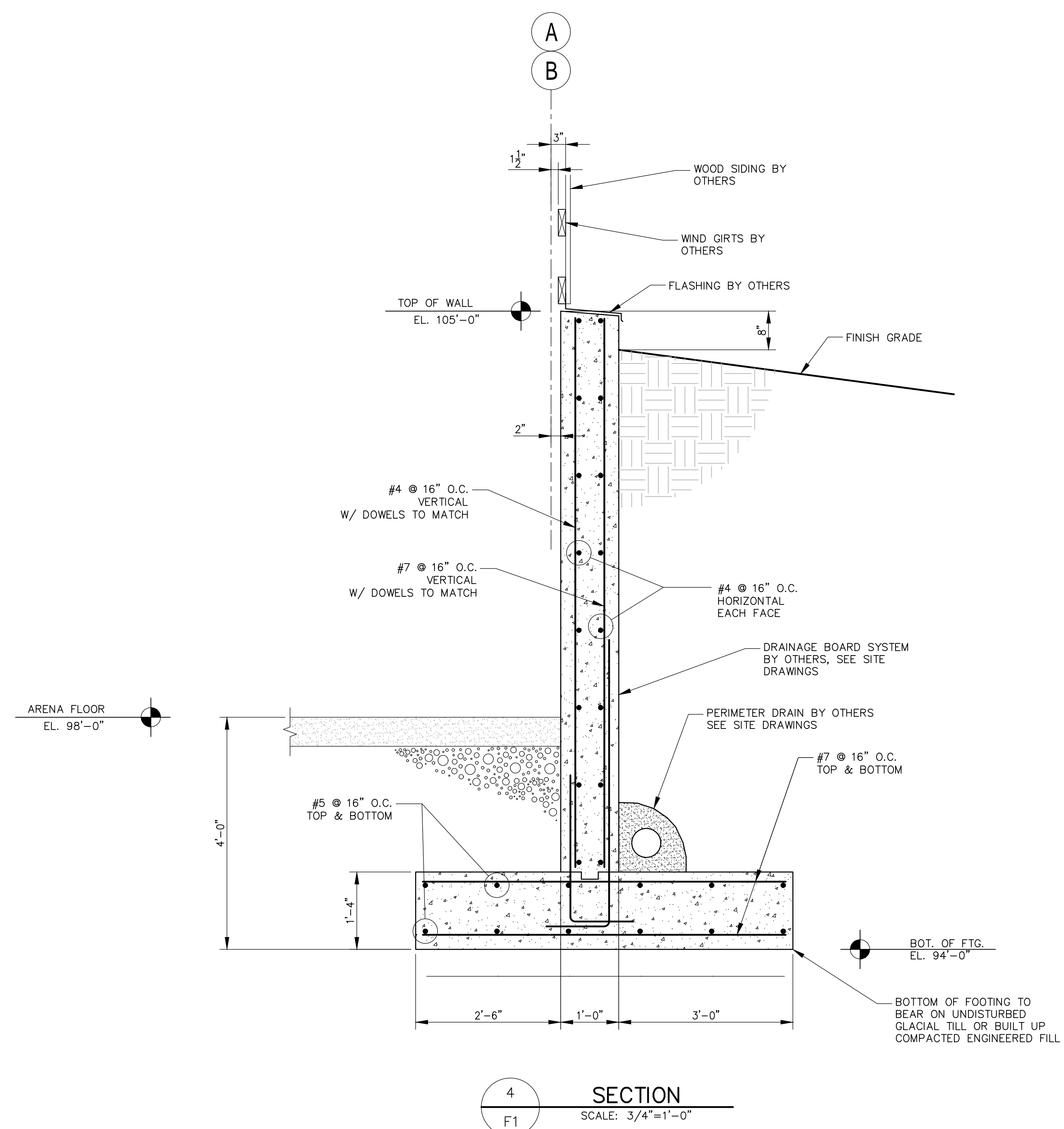
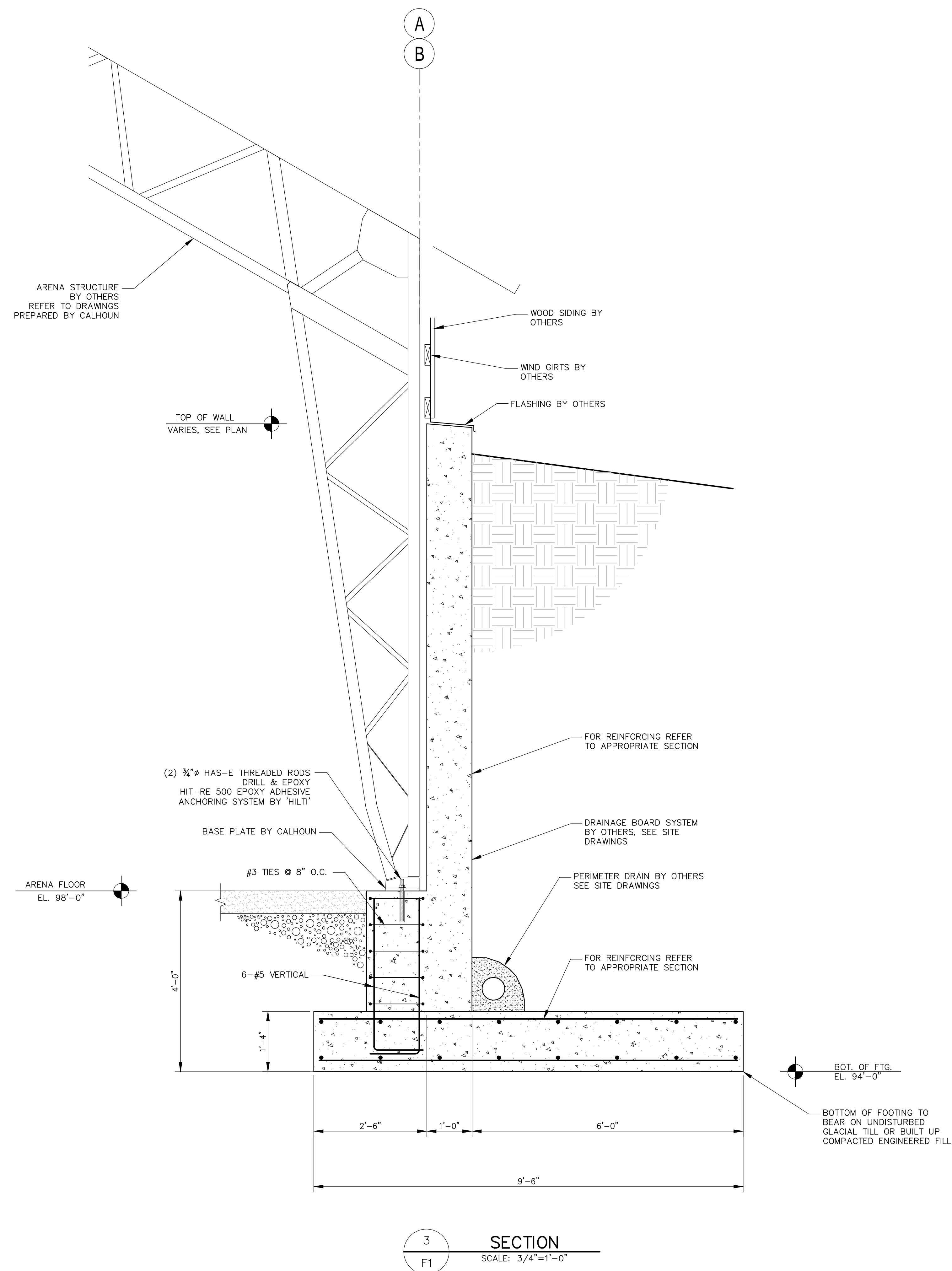

KEYPLAN

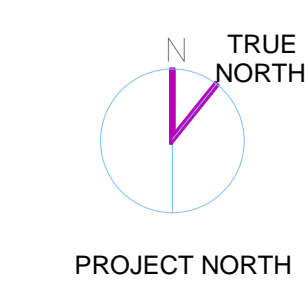

Scale:
Job No.:
Drawn By: MRF
Date:

F3

WILDSTAR FARM EQUESTRIAN FACILITY

SHERRORN MASSACHUSETTS



Polly Kornblith and Michael Newman
16 Nelson Hill Lane
Sherrorn, Massachusetts, 01770

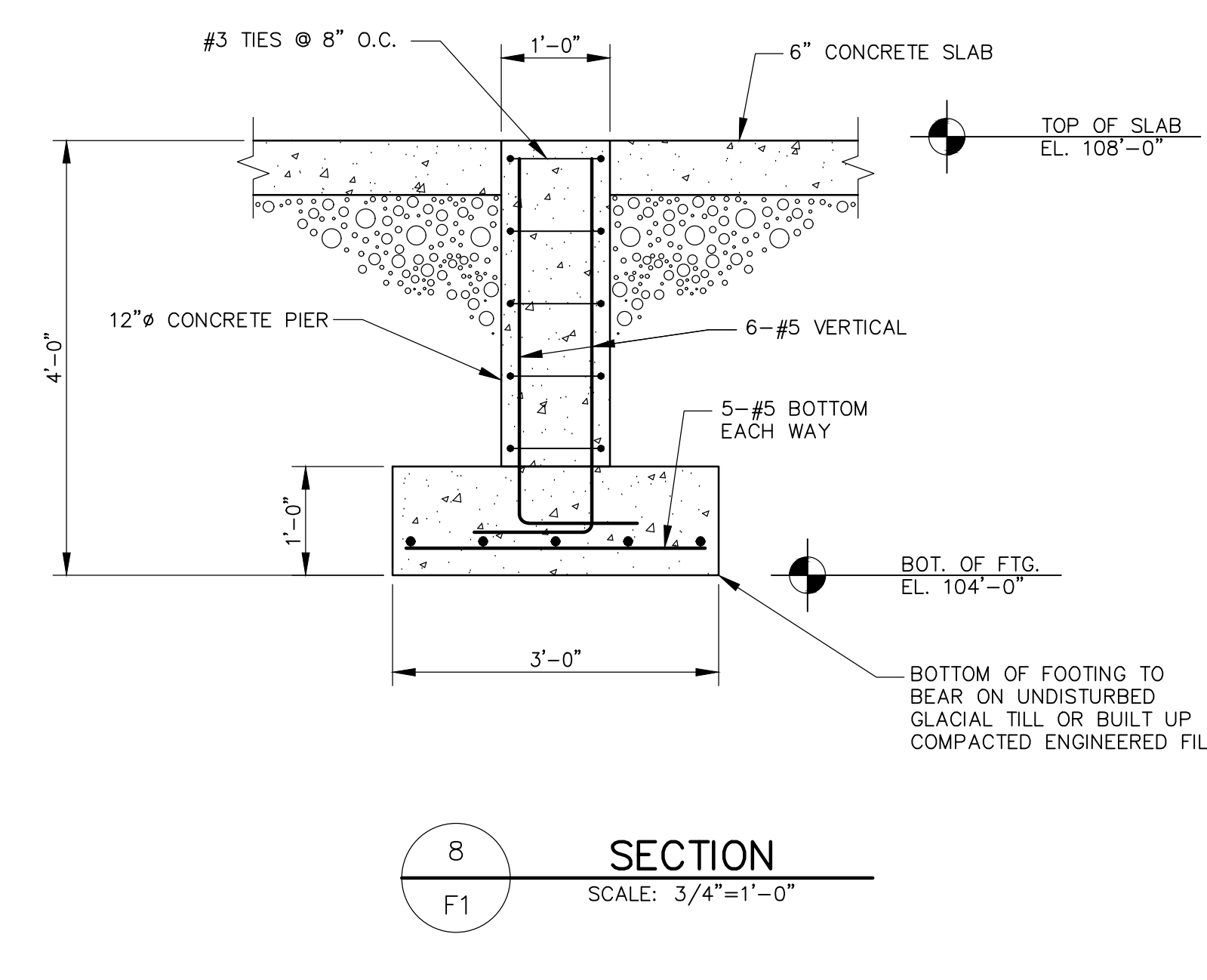
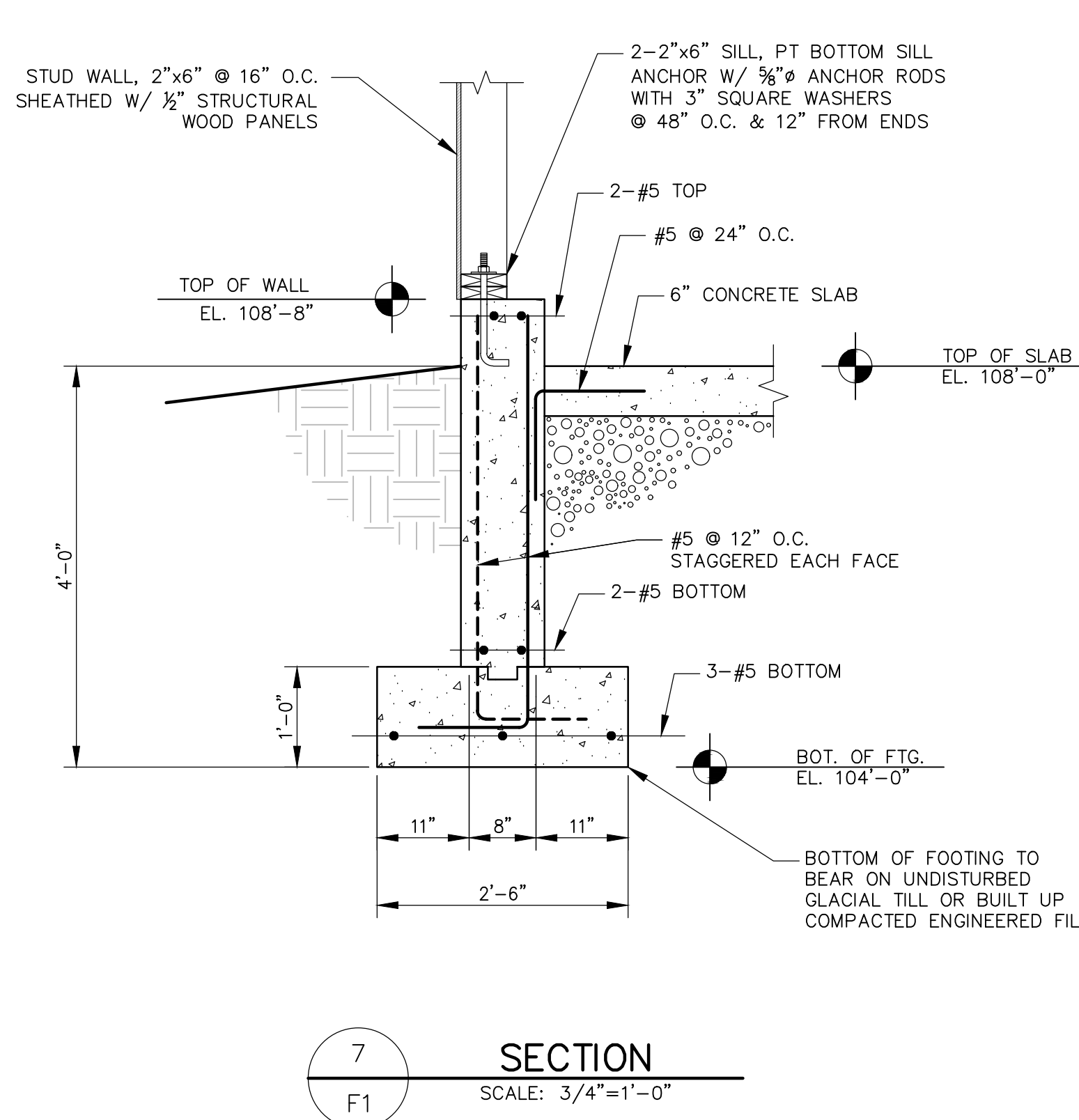
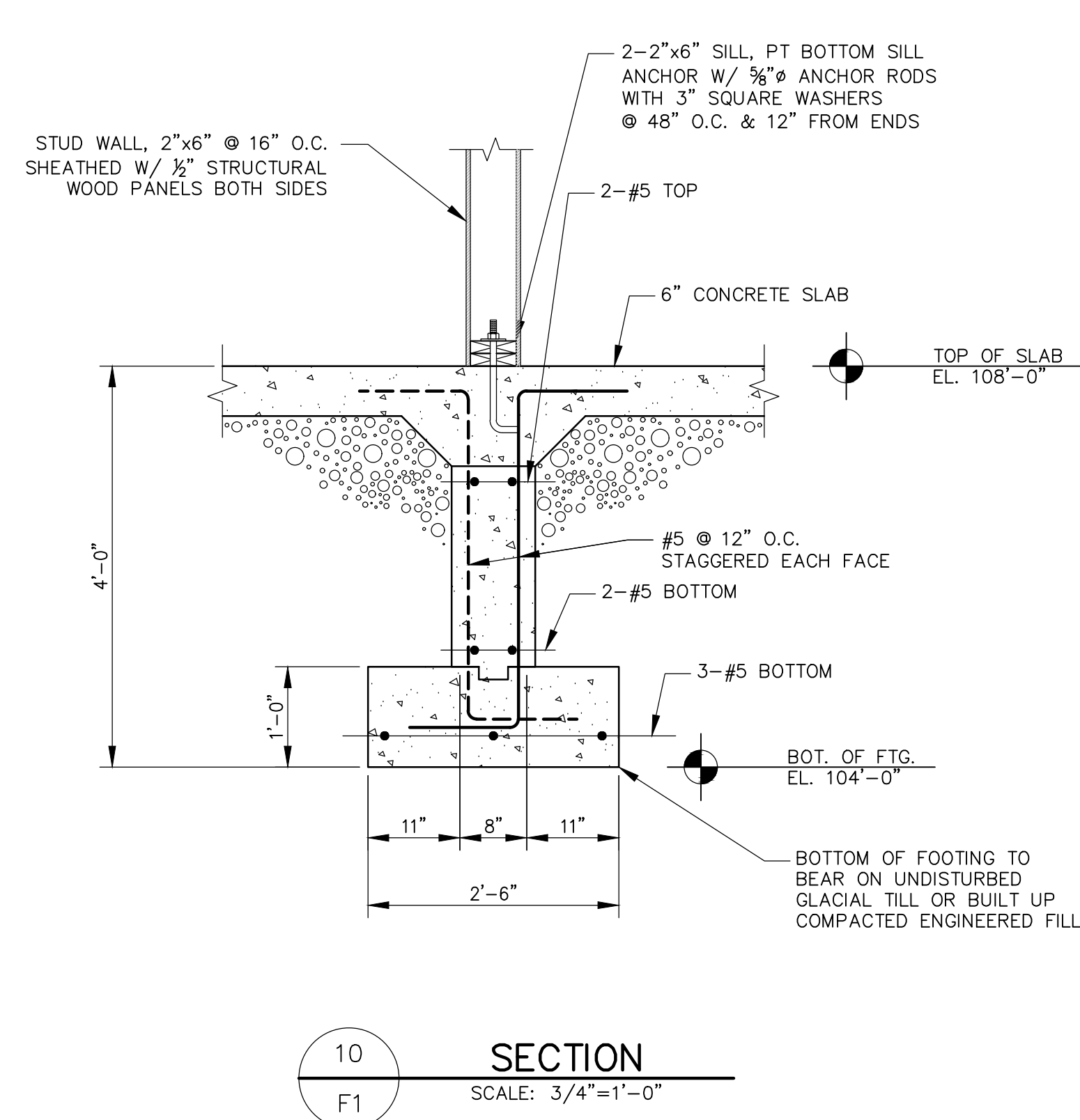
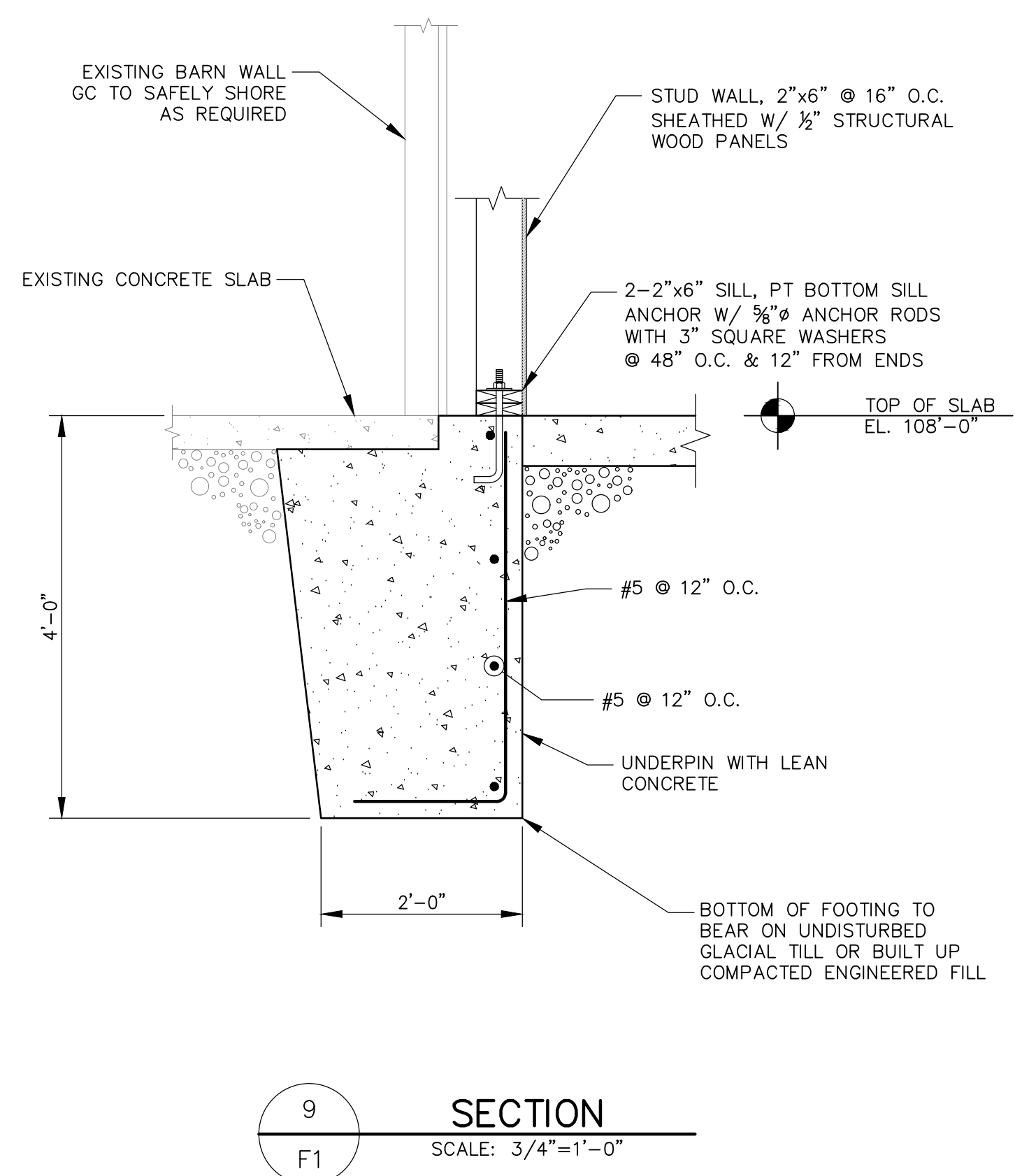
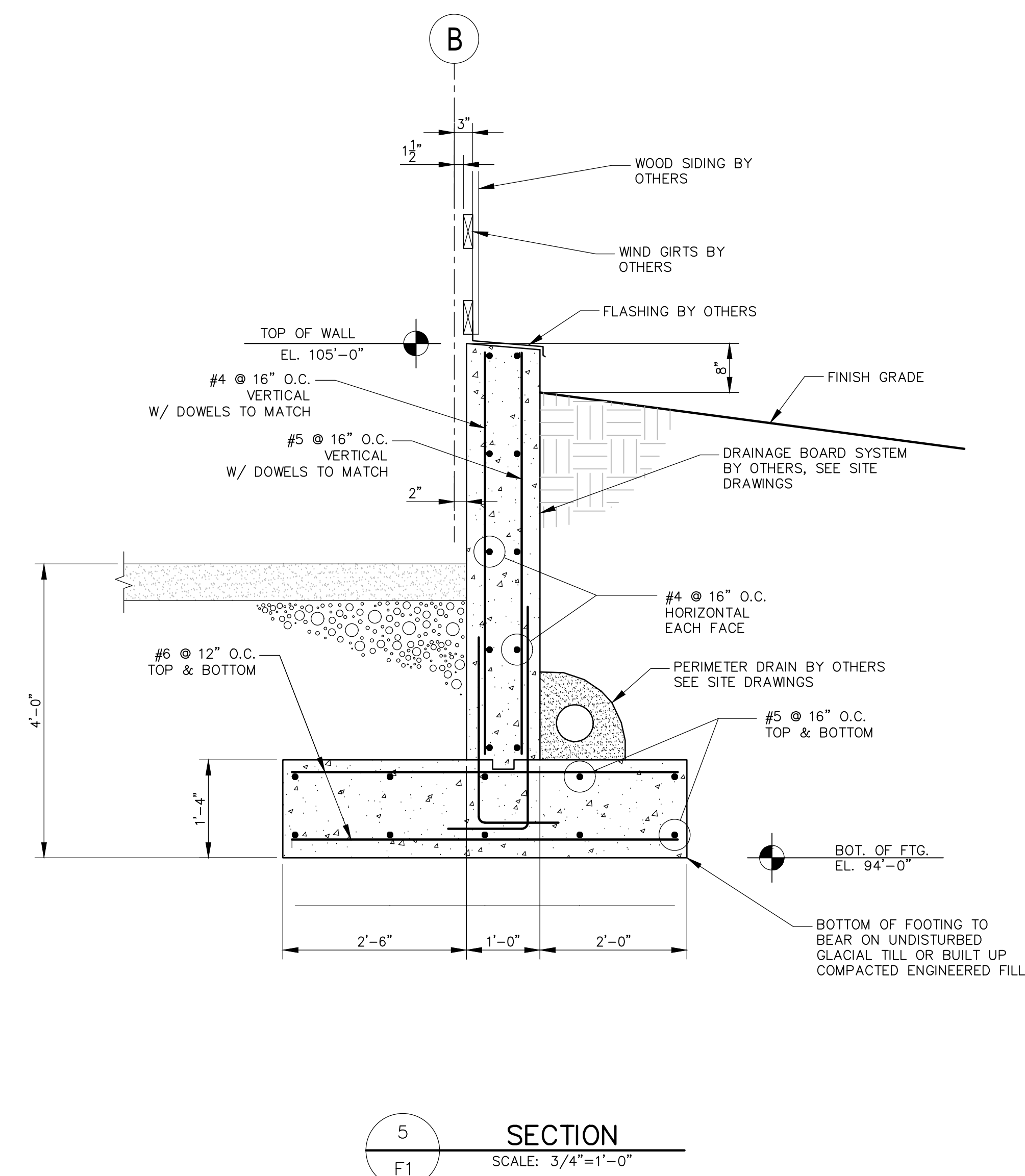
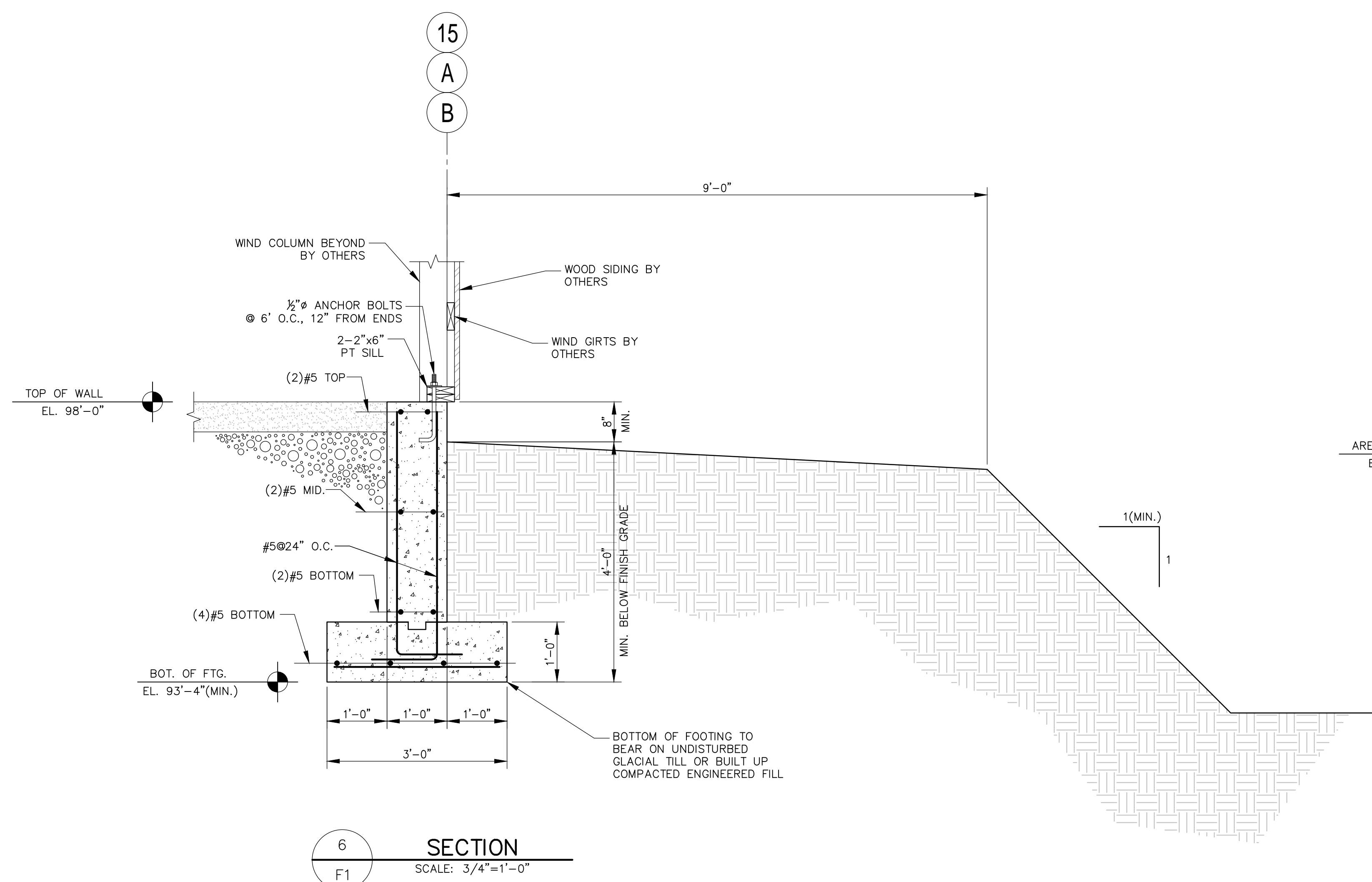
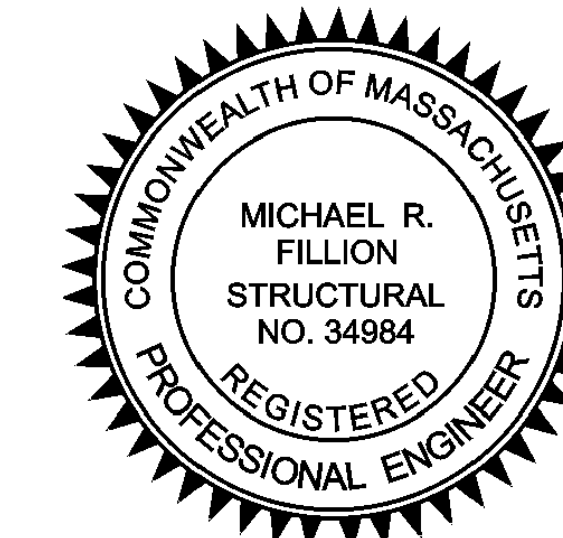

KEYPLAN

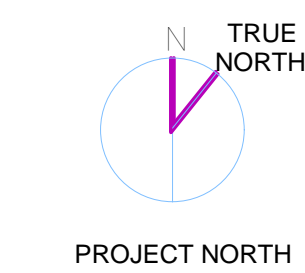

Scale:
Job No.:
Drawn By: MRF
Date:

F4

**WILDSTAR
FARM
EQUESTRIAN
FACILITY**

**SHERORN
MASSACHUSETTS**



Polly Kornblith and Michael Newman
16 Nason Hill Lane
Sherborn, Massachusetts, 01770



GENERAL NOTES

GENERAL

ALL MATERIALS, WORKMANSHIP AND DETAILS SHALL CONFORM TO THE LATEST EDITION OF THE MASSACHUSETTS STATE BUILDING CODE AND THE REFERENCE STANDARDS INCLUDED THEREIN THAT ARE APPLICABLE TO THIS PROJECT.

THE CONTRACTOR SHALL FAMILIARIZE HIMSELF WITH THE CONTRACT DRAWINGS. ANY DISCREPANCIES SHALL BE BROUGHT TO THE ATTENTION OF THE PROJECT ARCHITECT BEFORE PROCEEDING WITH THE AFFECTED WORK. ANY VARIATIONS OR SUBSTITUTIONS OF MATERIALS OR DETAILS FROM THOSE INDICATED ON THE DRAWINGS MAY BE MADE ONLY WITH PRIOR APPROVAL OF THE PROJECT ARCHITECT.

SHOP DRAWINGS FOR REINFORCING STEEL, (INCLUDING ALL ACCESSORIES) SHALL BE SUBMITTED TO THE ENGINEER AND A STAMPED APPROVAL RECEIVED BEFORE FABRICATION CAN PROCEED.

NO MAIN FRAMING OR STRUCTURAL MEMBERS ARE TO BE MODIFIED, ALTERED OR CUT WITHOUT THE APPROVAL OF THE PROJECT ENGINEER.

FOR EXACT LOCATION OF FLOOR AND ROOF OPENINGS, SEE ARCHITECTURAL, MECHANICAL, ELECTRICAL AND SHOP DRAWINGS.

THE CONTRACTOR SHALL BE RESPONSIBLE FOR ALL JOB SAFETY DURING CONSTRUCTION INCLUDING BUT NOT LIMITED TO SHEETING, SHORING AND DIVING STRUCTURES, BARRIERS AND SIGNAGE.

ALL STRUCTURAL DRAWINGS SHALL BE USED IN CONJUNCTION WITH THE ARCHITECTURAL, MECHANICAL, ELECTRICAL AND SHOP DRAWINGS AND SPECIFICATIONS.

UNLESS OTHERWISE INDICATED, DETAILS SHOWN ON ANY DRAWING ARE TO BE CONSIDERED TYPICAL FOR ALL SIMILAR CONDITIONS.

THE GENERAL CONTRACTOR SHALL BE RESPONSIBLE FOR ALL CONSTRUCTION MEANS, METHODS, CO-ORDINATION OF OTHER TRADES AND TECHNIQUES TO PRODUCE A SOUND AND QUALITY BUILDING. ALL DIMENSIONS, ELEVATIONS AND CONDITIONS MUST BE VERIFIED BY THE GENERAL CONTRACTOR OR RESPONSIBLE TRADES.

CODE

MASSACHUSETTS STATE BUILDING CODE, EIGHTH EDITION.

LOADS

SNOW: $P_s=40$ PSF
WIND: $V=105$ MPH
SECOND FLOOR LIVE: 40 PSF
DECK: 60 PSF

FOUNDATIONS

REFER TO THE GEOTECHNICAL REPORT AND RECOMMENDATIONS PREPARED FOR THIS PROJECT BY:

MOPHAU ASSOCIATES, LLC, DATED MARCH 24, 2017.

FOR PROPOSED EQUESTRIAN FACILITY, 16 NASON HILL LANE, SHERBORN, MA
THE STRUCTURE SHALL BE SUPPORTED ON NATURAL UNDISTURBED SOIL OR ON CONTROLLED GRANULAR BACKFILL BACKFILL COMPACTED ON THE NATURAL MATERIAL TO 95% MAXIMUM DRY DENSITY. THE MAXIMUM ALLOWABLE BEARING PRESSURE SHALL BE 2 TSP IN EITHER INSTANCE AND SHALL BE VERIFIED BY THE GENERAL CONTRACTOR. BOTTOM OF FOOTING ELEVATION SHALL BE 4'-0" MINIMUM BELOW FINISHED EXTERIOR GRADE.

PLACE BACKFILL SIMULTANEOUSLY ON BOTH SIDES OF FOUNDATION WALLS TO THE GRADES INDICATED. WHERE EXTERIOR GRADE IS MORE THAN TWO FEET BELOW SLAB, WALLS SHALL BE BRACED UNTIL SLAB TO WHICH THEY ARE CONNECTED IS AT LEAST TWO WEEKS OLD.

FOR LOCATIONS OF PIPES AND CONDUITS, SEE SITE, PLUMBING AND ELECTRICAL DRAWINGS. PIPES WHICH CARRY WATER SHALL NOT BE ALLOWED TO PASS UNDER FOOTINGS. STEP FOOTINGS APPROPRIATELY TO ALLOW PIPE TO PASS OVER FOOTING.

CONCRETE

CONCRETE SHALL BE PROPORTIONED, MIXED AND PLACED IN ACCORDANCE WITH ACI 318, "BUILDING CODE REQUIREMENTS FOR REINFORCED CONCRETE", AND ACI 301, "SPECIFICATIONS FOR STRUCTURAL CONCRETE FOR BUILDINGS", WITH A MAXIMUM SLUMP OF 4 1/2 INCHES.

MINIMUM COMPRESSIVE STRENGTH OF CONCRETE AT THE END OF 28 DAYS SHALL BE AS FOLLOWS:

STRENGTH (PSI)	MAXIMUM AGGREGATE SIZE (IN.)	ENTRAINED AIR (%)	SLAB ON GRADE
3500	1 1/2	0	ALL OTHER CONCRETE
3000	3/4	4 - 6	

NO ADMIXTURES OTHER THAN LOW RANGE WATER REDUCER WILL BE ALLOWED.

CONCRETE SHALL NOT BE CAST IN WATER OR ON FROZEN GROUND.

WELDED WIRE FABRIC SHALL BE LAID IN FLAT SHEETS AND CONFORM TO APPROVED PLACE WIRE FABRIC 1 INCH FROM THE TOP OF CONCRETE UNLESS OTHERWISE NOTED.

REINFORCING STEEL

ALL DETAILING, FABRICATION AND PLACING OF REINFORCING STEEL SHALL BE IN ACCORDANCE WITH THE LATEST ACI 318 "DETAILS AND DETAILING OF CONCRETE REINFORCING".

REINFORCING BARS SHALL BE NEW BILLET STEEL CONFORMING TO ASTM A615, GRADE 60. CLEAR CONCRETE COVER OVER BARS SHALL BE AS FOLLOWS UNLESS OTHERWISE NOTED ON THE DRAWINGS.

FOOTING	3 INCHES FROM BOTTOM
WALLS AND PIERS	2 INCHES FROM SIDES
SLABS	1 INCH FROM THE TOP

TIMBER FRAMING

TIMBER DESIGN SHALL CONFORM TO THE PROVISIONS OF THE 2005 NATIONAL DESIGN SPECIFICATION FOR WOOD CONSTRUCTION PUBLISHED BY THE AMERICAN FOREST AND PAPER ASSOCIATION.

TIMBER CONSTRUCTION SHALL CONFORM TO THE PROVISIONS OF THE 2005 WOOD CONSTRUCTION MANUAL FOR ONE AND TWO FAMILY DWELLINGS AND THE GUIDE TO WOOD CONSTRUCTION IN HIGH WIND AREAS FOR ONE AND TWO-FAMILY DWELLINGS PUBLISHED BY THE AMERICAN FOREST AND PAPER ASSOCIATION.

SHOP DRAWINGS FOR ALL ENGINEERED LUMBER PRODUCTS SHALL BE SUBMITTED INCLUDING BEAM TO BEAM CONNECTION HARDWARE.

NEW TIMBER FOR STRUCTURAL USE SHALL HAVE A MOISTURE CONTENT AS SPECIFIED IN THE "NATIONAL DESIGN SPECIFICATION FOR WOOD CONSTRUCTION" (NPPA, 1991 EDITION).

TIMBER CONSTRUCTION SHALL CONFORM TO CHAPTER 23 OF THE COMMONWEALTH OF MASSACHUSETTS STATE BUILDING CODE.

MATERIAL PROPERTIES SHALL CONFORM TO THE FOLLOWING:

- (A) FOR MEMBERS WITH NOMINAL 2" THICKNESS, S-P-F #1/#2 (5% MAX MC)
 - ALLOWABLE BENDING STRESS $F_b=875$ PSI (SINGLE MEMBER USE)
 - $F_b=1000$ PSI (MULTIPLE MEMBER USE)
 - ALLOWABLE SHEAR STRESS $F_v=70$ PSI
 - COMPRESSION PERPENDICULAR TO GRAIN = 425 PSI
 - MODULUS OF ELASTICITY $E=1,400,000$ PSI
- (B) FOR PRESSURE TREATED MEMBERS WITH NOMINAL 2" THICKNESS, SOUTHERN YELLOW PINE #1 OR BETTER (19% MAX MC)
 - ALLOWABLE BENDING STRESS $F_b=1300$ PSI
 - ALLOWABLE SHEAR STRESS $F_v=90$ PSI
 - COMPRESSION PARALLEL TO GRAIN = 1550 PSI
 - COMPRESSION PERPENDICULAR TO GRAIN= 565 PSI
 - MODULUS OF ELASTICITY $E=1,500,000$ PSI
- (C) 1-3/4" X 11-7/8" LVL ETC INDICATES LAMINATED VENEER LUMBER - 2.0E BEAM OR POST BY THE BOISE CASCADE COMPANY OR EQUAL
 - (C1) VERSA-LAM BEAMS (LVL)
 - ALLOWABLE BENDING STRESS $F_b=3080$ PSI
 - ALLOWABLE SHEAR $F_v=285$ PSI
 - MODULUS OF ELASTICITY $E=2,000,000$ PSI
 - (C2) VERSA-LAM COLUMNS (PSL)
 - ALLOWABLE BENDING STRESS $F_b=2200$ PSI
 - ALLOWABLE SHEAR STRESS $F_v=285$ PSI
 - COMPRESSION PARALLEL TO GRAIN $F_{c||}=3000$ PSI
 - COMPRESSION PERPENDICULAR TO GRAIN $F_{c\perp}=900$ PSI
 - MODULUS OF ELASTICITY $E=2,000,000$ PSI

"PT" INDICATES PRESSURE-TREATED LUMBER (TO BE USED WHEN IN CONTACT WITH CONCRETE, MASONRY, OR WEATHERED).

NO JOISTS OR BEAMS SHOULD BE NOTCHED OR DRILLED WITHOUT APPROVAL FROM THE SER

BUILT UP TIMBER BEAMS SHOULD BE FIRMLY NAILED OR BOLTED TOGETHER.

ALL HEADERS FOR INTERIOR OPENINGS SHALL BE 3-2X10

ALL HEADERS FOR EXTERIOR OPENINGS SHALL BE 3-2X12

MINIMUM BEARING FOR ALL JOISTS AND RAFTERS SHALL BE 3-1/2 INCHES.

USE DOUBLE JOIST UNDER ALL PARTITIONS.

BUILT UP BEAMS OF ENGINEERED LUMBER SHOULD BE NAILED OR BOLTED TOGETHER IN ACCORDANCE WITH THE MANUFACTURERS RECOMMENDATIONS.

TEMPORARY ERECTION BRACING SHALL BE PROVIDED TO HOLD STRUCTURAL TIMBER SECURELY IN POSITION AS DESCRIBED ON THE SHOP DRAWINGS. IT SHOULD NOT BE REMOVED UNTILL PERMANENT SUPPORT HAS BEEN INSTALLED.

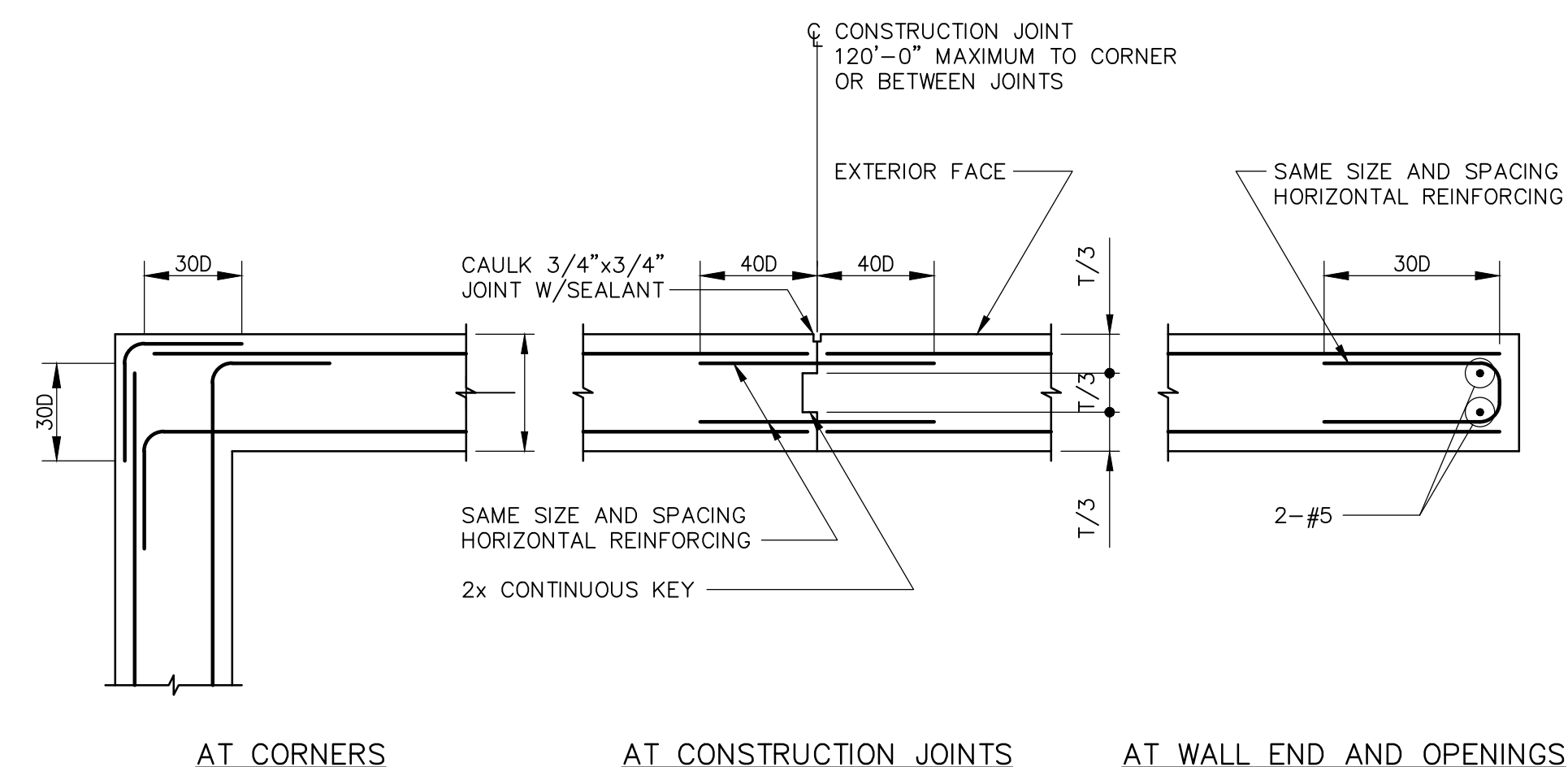

TYPICAL FOUNDATION WALL DETAILS
NO SCALE

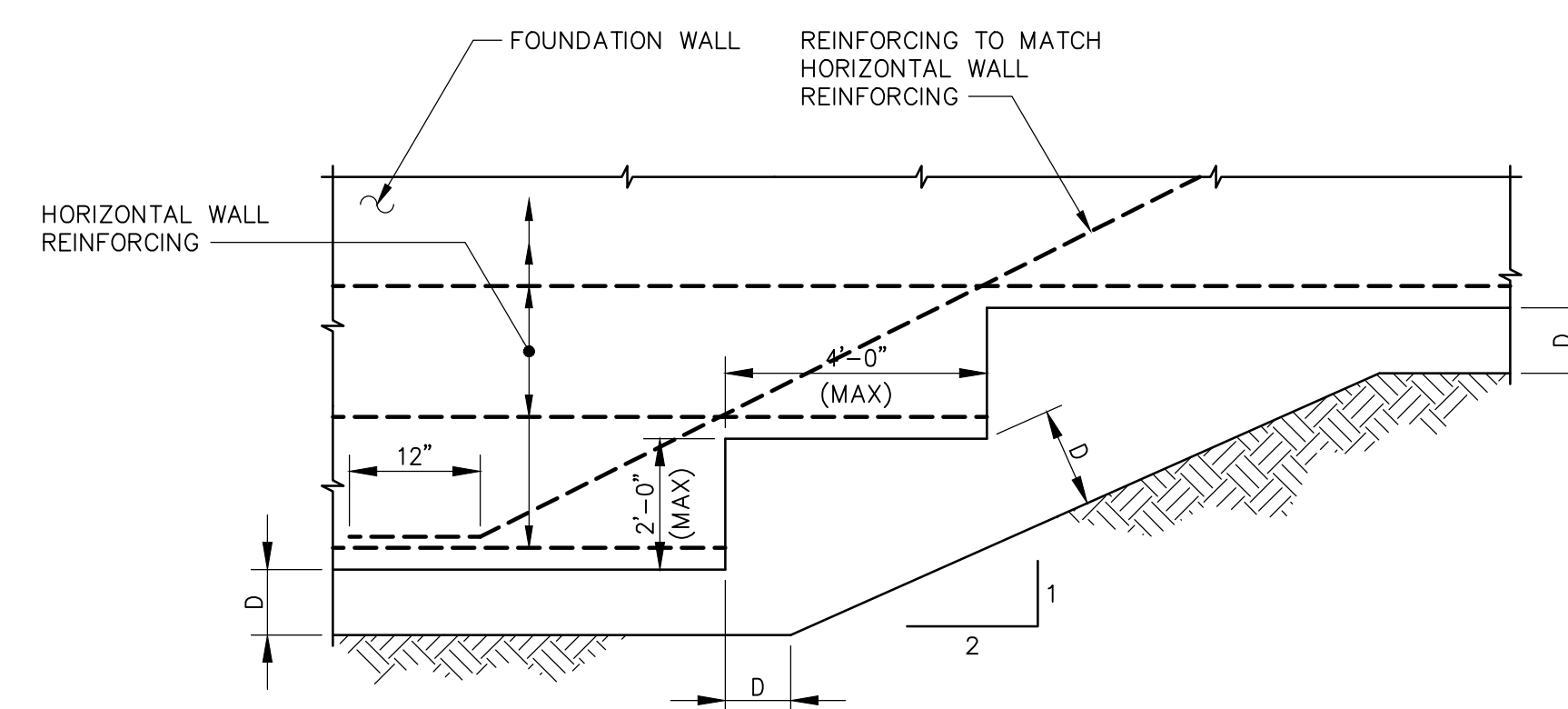

ELEVATION OF CONTINUOUS STEPPED WALL FOOTING
NO SCALE

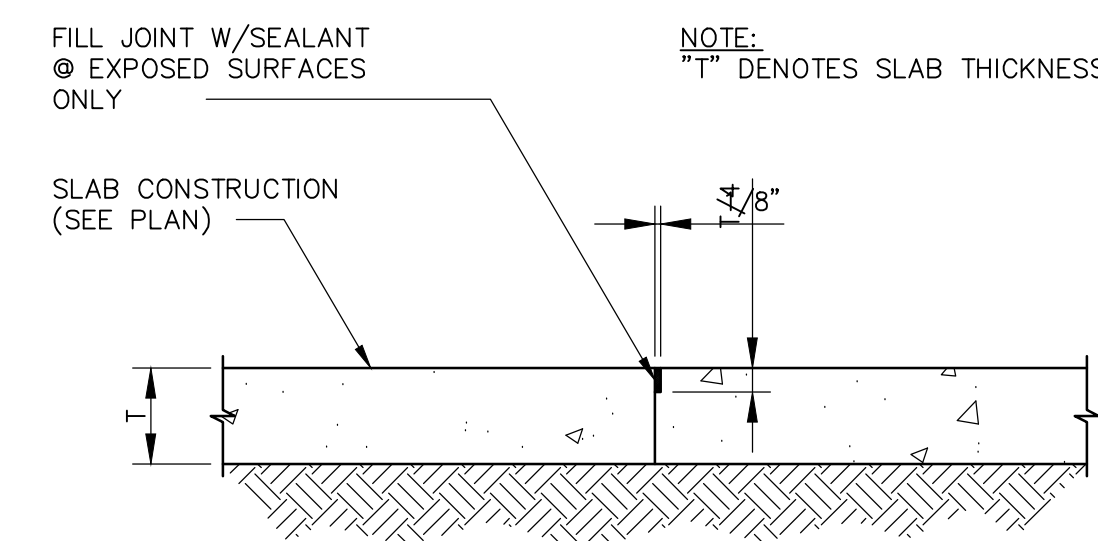

TYPICAL CONTROL JOINT DETAIL
NO SCALE

NOTE:
PLASTIC ZIP STRIPS MAY BE USED, JOINT SPACING IN EITHER DIRECTION SHALL NOT EXCEED 12 FEET.
ISOLATION JOINTS SHALL BE PLACED AT COLUMNS AND CONTROL JOINTS SHALL LINE UP WITH THEM.

KEYPLAN

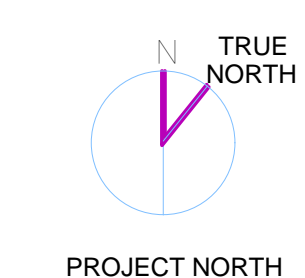

Scale:

Job No.:

Drawn By: MRF

Date:

F5